

# FORCED DRAFT GAS BURNERS

## HP SERIES FORCED DRAFT CAPACITIES THRU 3,000,000 B.T.U.

Short flame for best performance in all applications. Fires into long combustion chambers but also into shortest chambers. Increases efficiency.

Vacuum mixing method (Patent No. 3589845). Eliminates pulsation or "lifting"

Quieter operation. Smoother lightoff.

Adjustable input with regulator located in the gas valve.

Flange or pedestal mounting.

U.L. listed with Honeywell or Fireye controls. Controls to meet F.M., I.R.I. (F.I.A.) or special local codes also available.

1/3 H.P. 3450 R.P.M. Motor to HP-1000

1/2 H.P. 3450 R.P.M. Motor on HP-1500

3/4 H.P. 3450 R.P.M. Motor on HP-2500 and HP-3500

Low gas pressure design. Requires only 2.0"- 5.0" W.C. pressure. Eliminates need for elevated pressure.



Bottom mounted blower HP-2500 and HP-3500 (optional).

Flange  
HP-800,  
1000 (1500)

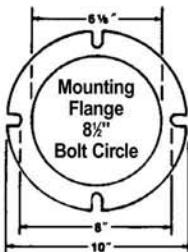

Flange  
HP-2500  
HP-3500

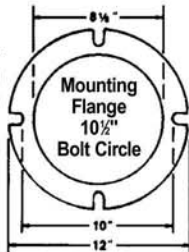

Model	BTU/Hr. Input		Gas Pipe Connection	Approximate Shipping Wt.
	Maximum	Minimum		
<b>NATURAL GAS</b>				
HP-800	800,000	300,000	1"	80 lbs.
HP-1000	1,000,000	300,000	1 1/4"	95 lbs.
HP-1500	1,700,000	500,000	1 1/4"	98 lbs.
<b>LIQUEFIED PETROLEUM GAS</b>				
HP-1000LP	1,000,000	300,000	1"	82 lbs.
HP-1500LP	1,700,000	500,000	1"	95 lbs.
<b>NATURAL GAS</b>				
HP-2500	2,500,000	1,000,000	2"	155 lbs.
HP-3500	3,500,000	1,000,000	2"	181 lbs.
<b>LIQUEFIED PETROLEUM GAS</b>				
HP-2500LP	2,500,000	1,000,000	1 1/4"	120 lbs.

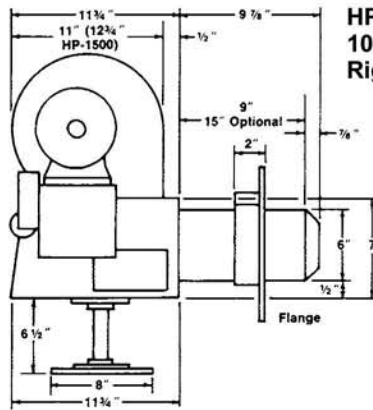

HP-800  
1000 (1500)  
Right Side

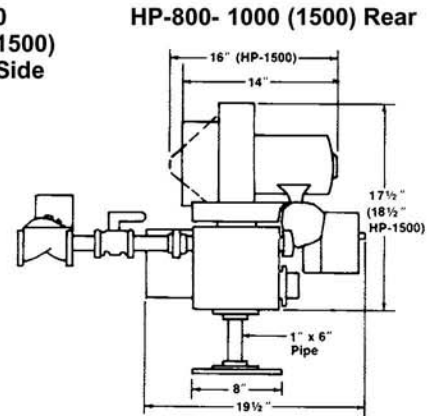

HP-800- 1000 (1500) Rear

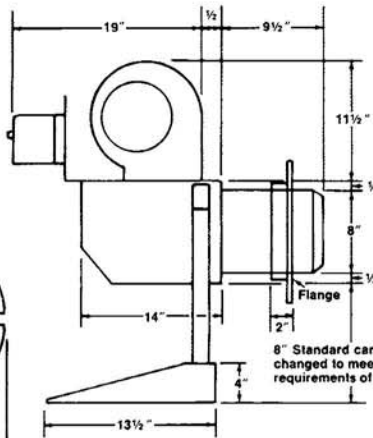

HP-2500  
HP-3500  
Right Side

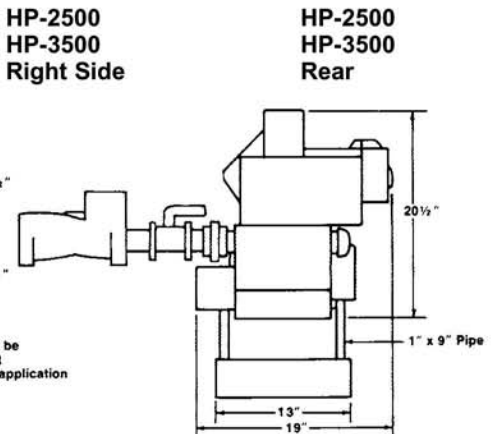

HP-2500  
HP-3500  
Rear

8" Standard can be changed to meet requirements of application

# ADAMS

Manufacturing Company

9790 Midwest Ave. • Cleveland, Ohio 44125

Telephone (216) 587-6801

FAX (216) 587-6807



Distributed by